

A Higher Level of Performance



Data Sheet - South Korea

MiniWave Ultrasonic Level Series

Liquid Level Measurement



For more information, please visit >
www.hawkmeasure.com

Overview

MiniWave Ultrasonic Level Series



Overview

MiniWave is a compact, loop-powered ultrasonic level transmitter for continuous measurement of liquids. As a price leader, it does not compromise on good value; and provides effortless and intuitive operation. Easy and flexible mounting combined with high chemical compatibility and 12 metres (40ft) measuring range makes the MiniWave suitable in multiple applications in all industries.

Principle of Operation

The MiniWave emits an ultrasonic pulse, which is reflected from the surface of the liquid being measured. The reflected signal is processed using specially developed software to enhance the correct signal and reject false echoes.

Adaptive sensitivity control allows the unit to dynamically adjust and improve the received echoes for the best possible measurement outcome.

Function

The MiniWave is a non-intrusive level transmitter for measuring level of liquids.

Primary Areas of Application

Liquid Level:

- River level
- Wet wells
- Inlet screens
- Tanks
- Sumps
- Pump stations
- Water towers
- Dams
- Basin levels
- Chemical storage

Features

- 2 wire 4-20mA with HART
- Maximum range to 12 metres (40ft)
- Non-contact measurement
- Low cost per measuring point
- Auto compensation for steam and signal losses
- Ingress protection class IP67, NEMA 4x
- Adaptive sensitivity control
- Volume linearization to tank shapes or 32 point table

Part Numbering

Model Type

MW Miniwave, 4-20mA with HART

Process Connection

N1A 2" NPT thread
B1A 2" BSPT Thread
FU1K Universal Flange

Accessories

- MAKFF - Mounting Accessory Kit



Liquid Level Measurement

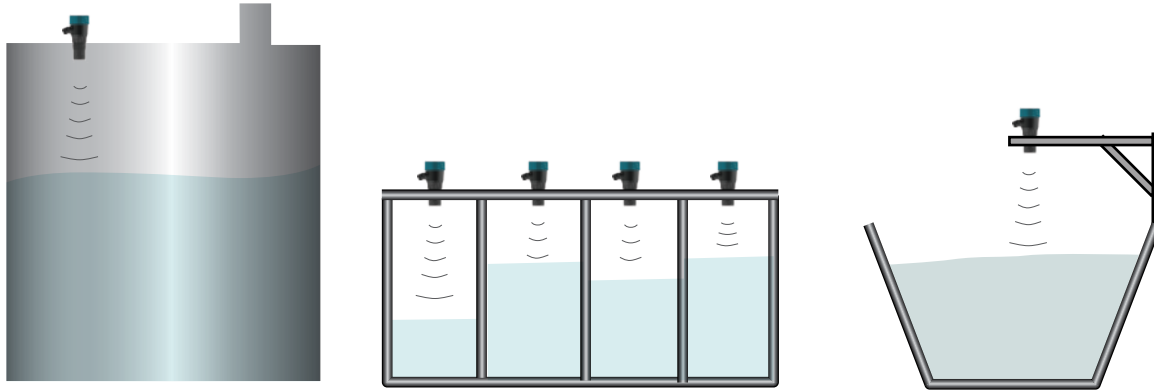

Mounting

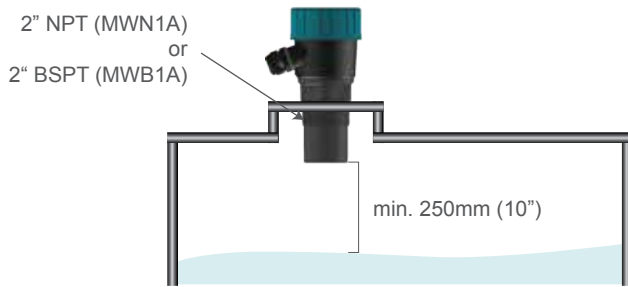

Flange (optional)

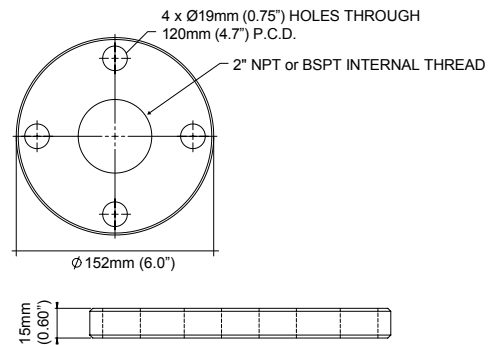

Dimensions

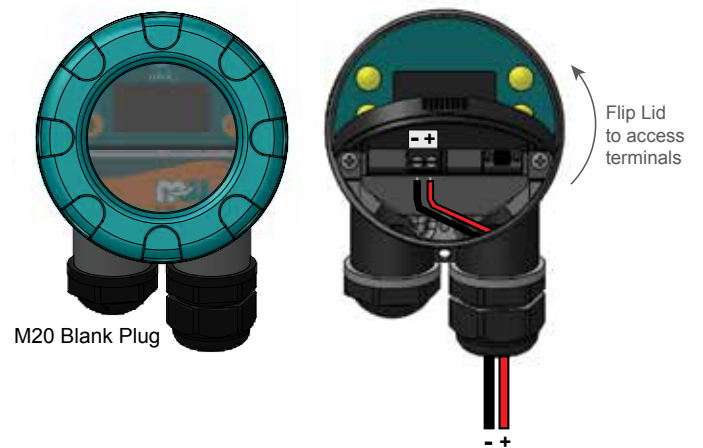
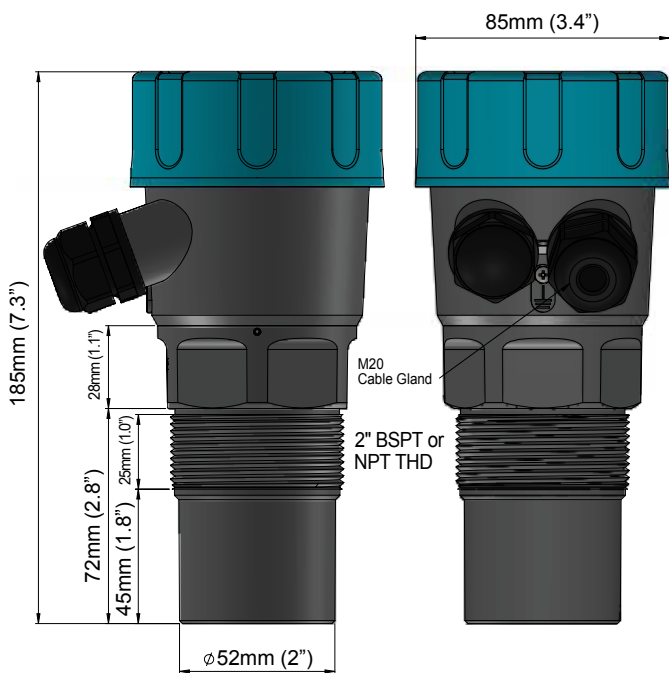

Specifications

MiniWave Ultrasonic Level Series



Frequency

- 50 kHz

Operating Voltage

- 7 - 28VDC at the terminal (residual ripple no greater than 100mV)

Power Consumption

- 500mW @ 24VDC

Analog Output

- 4 -20mA modulating output module with HART
(Recommended 250 Ohm @ 24VDC)

Analog Resolution

- 14 bits

Communications

- 4 -20mA with HART

Blanking Distance

- 250 mm (10 inch)

Maximum Range

- 12 metres (40ft)

Resolution

- 1 mm (0.04")

Electronic Accuracy

- +/- 0.2% of maximum range (full span)

Operating Temperature

- -40°C to 60°C

Maximum Operating Pressure

- -0.5 to 3 bar (0 - 44 PSI)

Beam Angle

- 7°

Materials

- Transducer: PVDF
- Housing: Powder coated aluminium

Display

- 4 line graphic display

Keypad

- 4 keys = CAL, RUN, UP, DOWN

Memory

- >10 years data retention

Enclosure Sealing

- IP67

Cable Entries

- M20 cable glands

Mounting

- MWFU1K - MiniWave with Universal Flange

Typical Weight

1kg (2.2 pounds)

Volume

- Pre-set common vessel shapes
- 32 point programmable linearization table
- Requires PC connection with GoshawkII software

Measurement Speed

- Approximately 2 measurements per second @ 20mA

Response Time

- <2 seconds at 4mA
- <1 second at 20mA

Hawk Measurement Systems (Head Office)

15 - 17 Maurice Court
Nunawading VIC 3131, AUSTRALIA

Phone: +61 3 9873 4750

Fax: +61 3 9873 4538

info@hawk.com.au

For more information and global representatives: www.hawkmeasure.com

Additional product warranty and application guarantees upon request.

Technical data subject to change without notice.

Hawk Measurement

90 Glenn Street
Suite 100B, Lawrence, MA 01843, USA

Phone: +1 888 HAWKLEVEL (1-888-429-5538)

Phone: +1 978 304 3000

Fax: +1 978 304 1462

info@hawkmeasure.com

Represented by:

